



ALLUMINIO “TAGLIO TERMICO”

SISTEMA RX 700



Permeabilità all'aria

classe raggiunta	1	2	3	4
pressione applicata	(150Pa)	(300Pa)	(450Pa)	(600Pa)



Resistenza al carico del Vento

classe raggiunta	C1	C2	C3	C4	C5
freccia di flessione (1/150)	A1	A2	A3	A4	A5
freccia di flessione (1/200)	B1	B2	B3	B4	B5
freccia di flessione (1/300)	C1	C2	C3	C4	C5
pressione applicata	(400Pa)	(800Pa)	(1200Pa)	(1500Pa)	(2000Pa)



Tenuta all'acqua

classe raggiunta	1A	2A	3A	4A	5A
pressione d'aria	(0Pa)	(50Pa)	(100Pa)	(150Pa)	(200Pa)
km/h	0	32,2	45,53	56,67	64,39
E900	E1050	E1200	E1350	E1500	
(900Pa)	(1050Pa)	(1200Pa)	(1350Pa)	(1500Pa)	
136,6	145	160	165	178	



Trasmittanza Termica

Prestazione Raggiungibile					
Zona Climatica	A	B	C	D	E



Prestazione acustica

Isolamento Acustico	<= 40 dB	fino a 41 dB	fino a 42 dB	fino a 44 dB	fino a 45 dB
Prestazione Raggiungibile					

Finestra e portafinestra apertura interna

Telaio / anta finestra – portafinestra

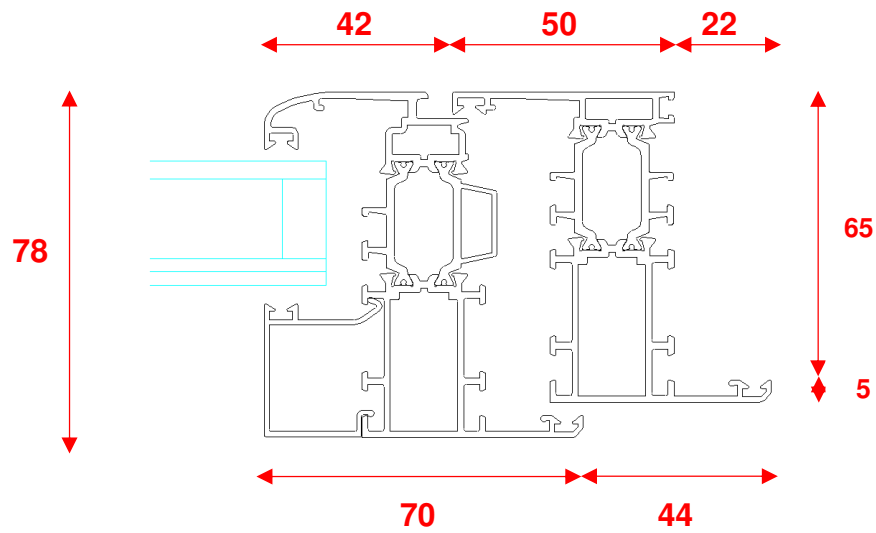

Nodo centrale

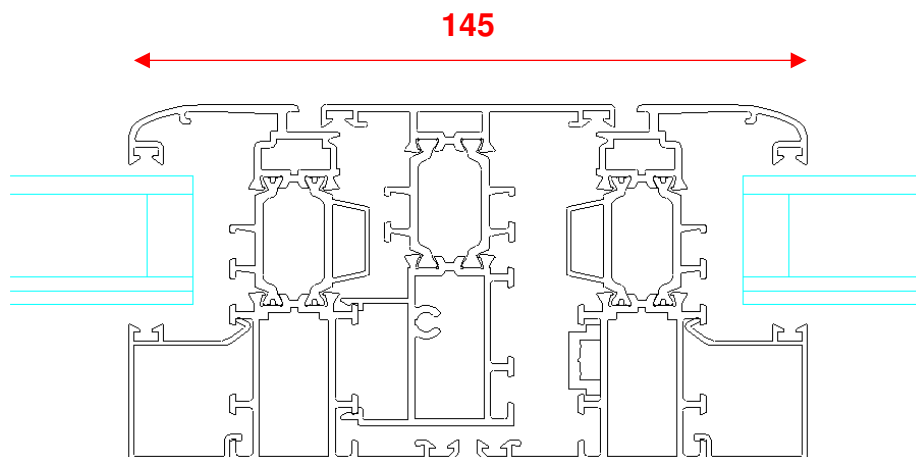

Porta apertura interna

Telaio / anta porta

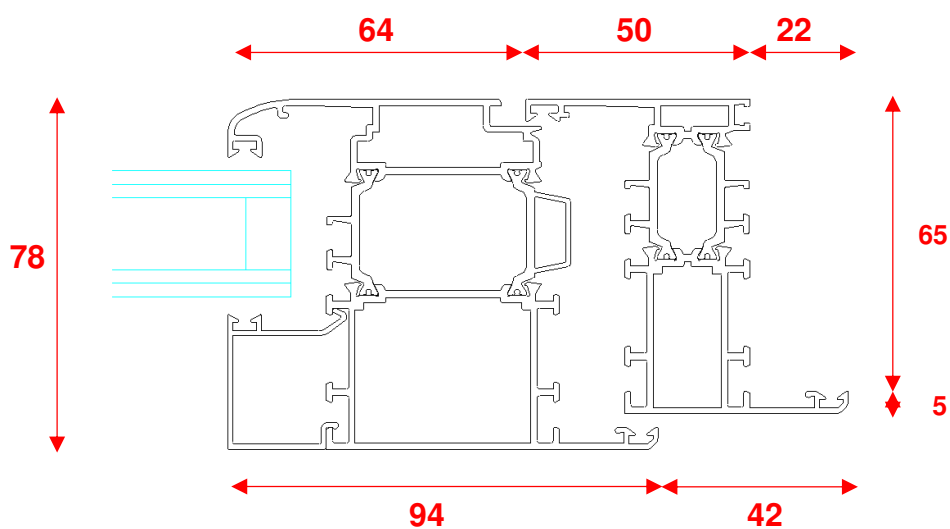

Nodo centrale

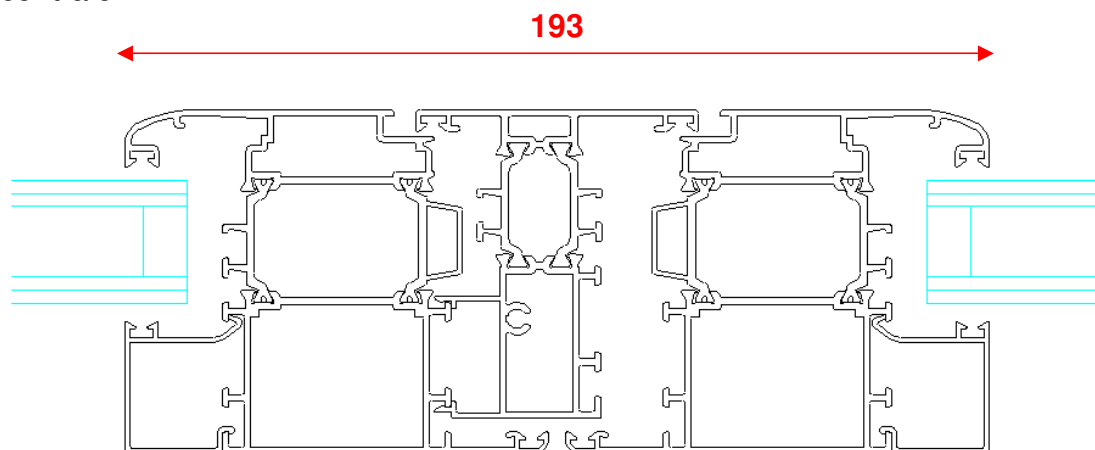

Fascia

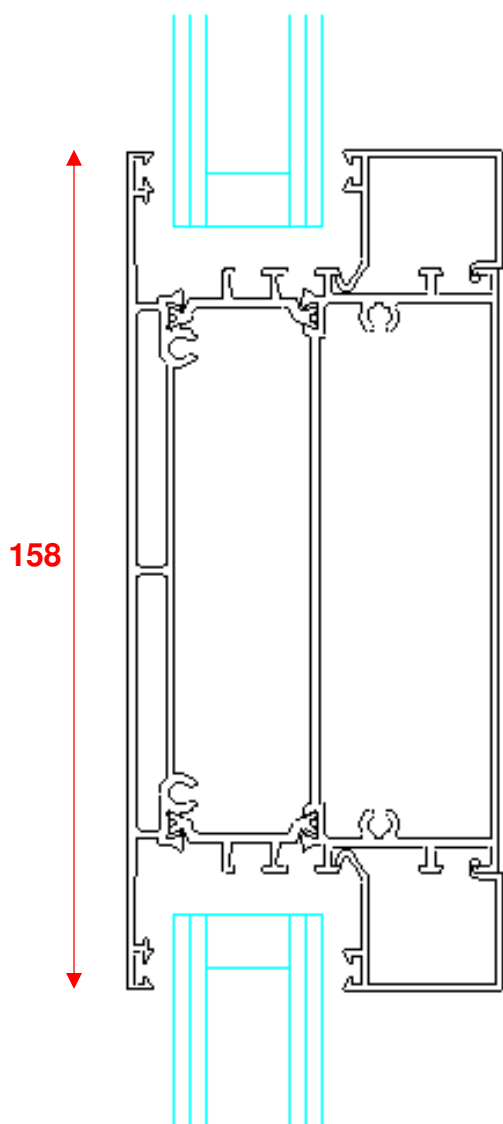

Zoccolo

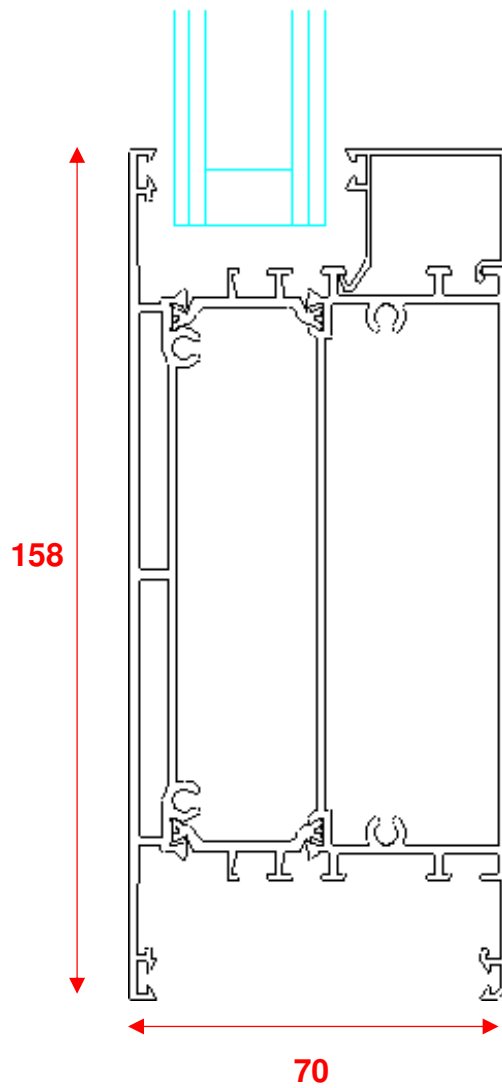

Soglia ribassata

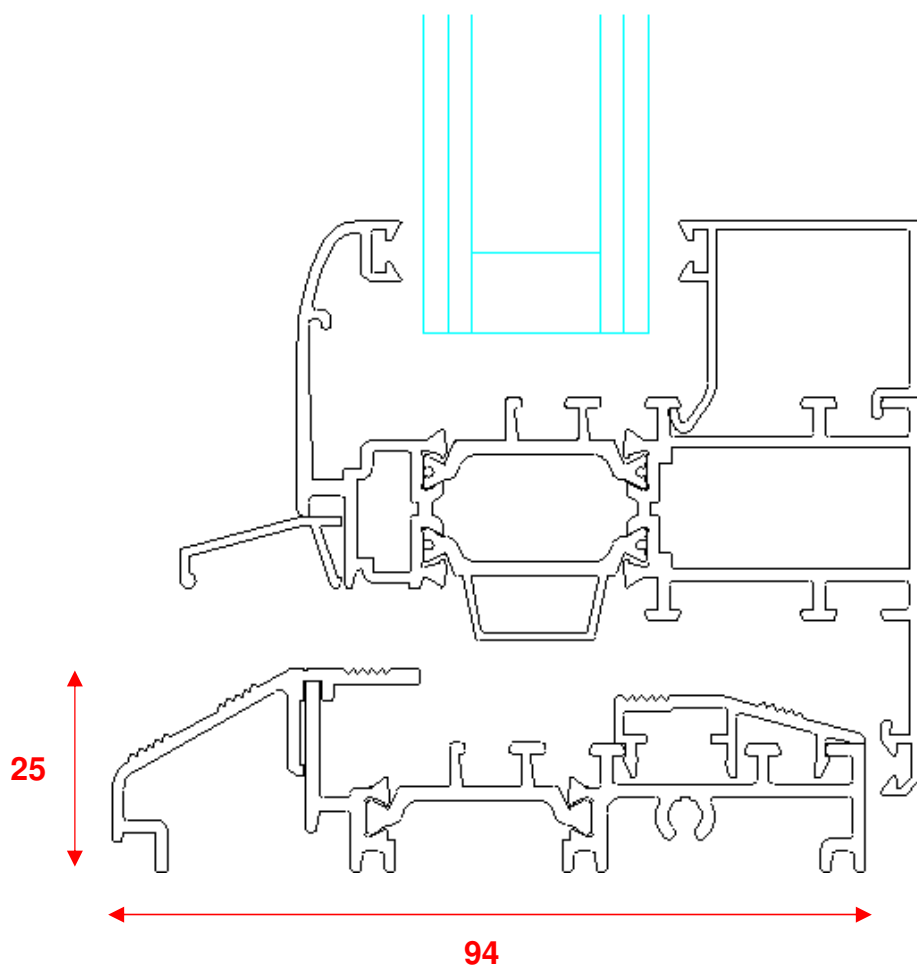

Opzione telai con aletta battuta maggiorata

